

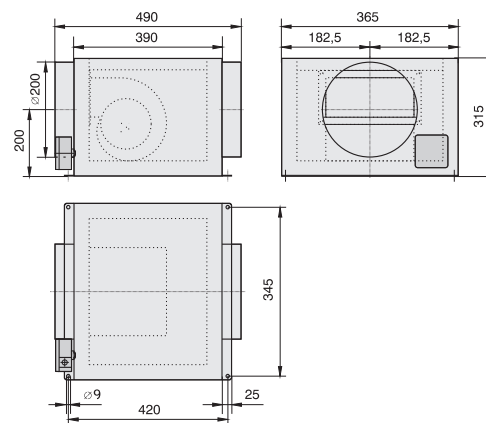

Typ / Type : Z 200 E1		Art.-Nr. / Art.-No. : F05-20007	
U	230V (50Hz)	Δp _{fa} min	– Pa
P ₁	0.21 kW	ΔI	– %
I _N	0.90 A	I _A / I _N	1.1
n	1440 min ⁻¹		IP44
C _{400V}	4 μF		01.009
t _R	50 °C		14.0 kg



LWA _{rel} A-bewertet bei V=0,5*V _{max} LWA _{rel} A-weighted at V=0,5*V _{max}	fM [Hz]						
	125	250	500	1K	2K	4K	8K
LWA ₂ [dB(A)] Gehäuse / casing	43	42	38	36	33	28	23
LWA ₅ [dB(A)] Ansaugseite / inlet side	48	46	43	42	41	39	32
LWA ₆ [dB(A)] Ausblasseite / outlet side	53	59	62	65	67	62	56